

**MAHLE**

FluidPRO®

for oil change in  
automatic transmission

New  
ATX Line  
2022



# MAHLE FluidPRO®

Introduce the oil restoration service in automatic transmission systems to your workshop. Thanks to the ATX line from MAHLE you are assured of maximum professionalism and great ease of use.

Oil change  
stations  
ATX 280  
ATX 250  
ATX 190

## Why do car manufacturers recommend periodic oil changes in automatic transmission system?

- To ensure a more comfortable ride
- To extend the life and high efficiency of the automatic transmission
- To prevent system malfunctions due to gearbox oil wear

## Benefits at a glance



Line of fully automatic stations



Automatic flow direction detection



New web database with images of junction points



Everything under control with the ATF Remote Viewer App (ATX 280)



Exclusive recovery/recharge system (patented)



Dual pump: maximum performance in emptying the gearbox and the used oil tank (ATX 280)



Wide coverage guaranteed by multi-brand adapters system



Sump Oil Recovery Function



Zero Cross-Contamination guaranteed



Full Print Report



# Full Functionality

## Zero Cross Contamination



The Zero Cross-Contamination function guarantees 100% cleanliness, removing oil and other types of residues, preventing possible serious damage to the automatic transmission.

With the ATX stations, you can be sure that the gearbox is always filled with oil that is free from contamination.

Interchangeable oil canisters, equipped with a quick-connect system, ensure rapid preparation of new oil and immediate station operation.

## Current Cycle Back Up Function



No time wasted! If an interruption occurs during an oil change procedure, flushing will be resumed from the last completed step, avoiding the need to repeat the entire cycle (ATX 280 only).

## FluidPRO® ATX Remote Viewer App



The new FluidPRO® ATX Remote Viewer App allows the operator to freely control all execution steps. Completely renewed in its graphics, it makes the control of the station operation accessible at any time.

## Report printing



At the end of the gearbox oil service, ATX MAHLE stations generate a full-color A4 "Service Report" that can be easily sent via WiFi (ATX 280) or exported to a USB stick (ATX 250; ATX 190).

## Dipstick function



The Dipstick function allows you to work on sealed transmission systems, where the only access is the dedicated dipstick (ATX 280 only).



## Renewed Web Graphical Database

The WEB Databank provides complete instructions for the flushing process:

- Connection procedure with images
- Technical Information
- Filter Removal Procedure
- Level Procedure
- Selector lever release procedure
- Hybrid Engine Management

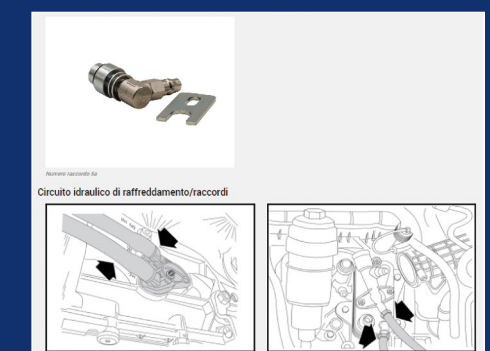
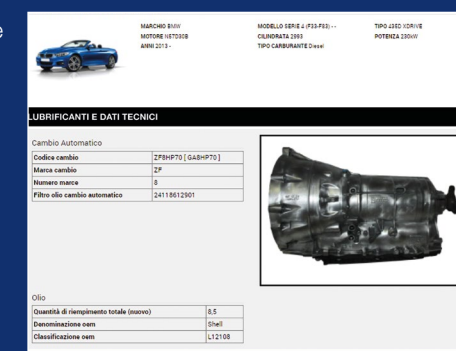



# ATX 280

Fully automatic, simple to use. Now with WiFi connection and Touch display.

New design for the FluidPRO® ATX line, which, thanks to the large 7" touch screen display and a new graphic interface, allows the operator to make any automatic transmission oil flushing operation even simpler and more automatic.

The station is equipped with two pumps, for excellent performance and optimization of its characteristic functions, such as:

- Built-in Dipstick function for working on sealed transmission systems;
- Boost function, which boosts used oil drainage, speeding up oil change operations.
- Quick Discharge function: maximum speed in emptying the used oil tank

The WiFi connection enables the connection to the WEB Databank (included in the first year), constant updates and remote assistance (Re.Solve), as well as the possibility to print the final report directly from your workshop's PC (Nexus Print).

The provision of the complete online database, renewed in its graphics, provides complete instructions and information, supported by detailed images of each procedure.

The new FluidPRO® ATX Remote Viewer App (included as standard) allows the operator to freely view all execution steps.



Adapters Kit 1-17  
included in sales configuration

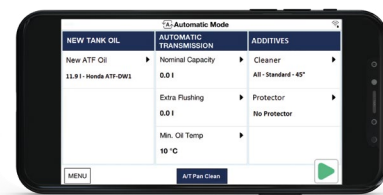

The oil drain grate is designed to conveniently accommodate the tools and fittings needed during operation.

Technical Data	
Type of service	Automatic and fully guided, 7" color touch display
New oil filter	90µ mesh filter
Inspection windows	Oil quality visual control
Dipstick function	Integrated with ø6mm and ø10mm tubes
Zero-Cross Contamination	Circuit flushing function after each oil type change
Hoses	2 x 3 m (service hoses), 1 x 1.5 m (for waste oil drainage)
BOOST function	Integrated
Service report printing	Via WiFi (with Nexus print), export via USB to flash drive
Upper grate	With joints holder functionality
Oil pump	2 x 10 l/min hydraulic pumps each; PWM controlled
Languages Menu	15 different languages
Power supply	90/240 VAC, 50-60Hz
SW and Service Update	Re.Solve via WiFi connection
Smartphone App	FluidPRO® ATX Remote Viewer
Dimensions/weight (H X B X T)	120 x 74 x 74 cm, 62 kg

# ATX 250

The simplest, but great performance. To introduce a high profitability service on the shop floor.

Small, but powerful. Ideal for bringing ATF transmission service to the shop for the first time.

As in the most advanced model, sophisticated electronics guide all phases of operation, activating the special functions that optimize the final result.

Integrated database with technical information (oil quantity, oil type, tightening torques, oil filter code) and indication of the type of fittings to be connected to the gearbox

The station enables the automatic detection of oil flow direction in the transmission and prevents any damage to the system.

The exclusive software that guides the recovery/recharge processes (patented) allows for maximum performance on every type of ATF transmission.

Also in the ATX 250, the new FluidPRO® ATX Remote Viewer App (optional) can be activated, allowing the operator to freely control all running steps.

Maximum control over new oil contamination is guaranteed by the Zero Cross-Contamination function (internal flushing of the circuit and external hoses), as well as by the interchangeable oil canister replacement system.



Adapters Kit 1-17  
included in the sales configuration



A wide range of Adapters, available in kit and single packs, enable the range ATX to cover a wide range of vehicles

Technical Data	
Type of service	Automatic and fully guided, 4.3" color display, keyboard
New oil filter	90µ mesh filter
Inspection windows	Oil quality visual control
Dipstick function	Integrated with ø6mm and ø10mm tubes
Zero-Cross Contamination	Circuit flushing function after each oil type change
Hoses	2 x 3 m (service hoses)
BOOST function	--
Service report printing	Export to USB flash drive
Upper grate	grate
Oil pump	1 10 l/min hydraulic pump; PWM controlled
Languages Menu	15 different languages
Power supply	90/240 VAC, 50-60Hz
SW Update   Service	USB Type A   USB Type B
Smartphone App	FluidPRO® ATX Remote Viewer
Dimensions/weight (H X B X T)	120 x 74 x 74 cm, 62 kg

# ATX 190



## The ATF station approved by Mercedes-Benz.

The Mercedes-Benz service manual recommends regular oil changes on automatic transmissions.

Station ATX 190 by MAHLE meets all the requirements of the car manufacturer, which has therefore approved its introduction in its authorized workshops.

The simple and intuitive operation guides the user quickly through the entire automatic service procedure, with step-by-step instructions that mirror the manufacturer's specific procedure.

Transmission flushing and oil change are performed easily and completely (flushing with oil only - no additives).

Dedicated App increases productivity on the shop floor.

Visualization of process steps directly on the display or via App on smartphones, whether you are near the vehicle or inside it.

Interchangeable canister for quick change of oil types and guaranteed purity through an internal washing process (Zero-cross).

Automatic detection of oil flow direction in the transmission.



### Technical Data

Type of service	Automatic and fully guided, 4.3" color display, keyboard
New oil filter	MAHLE filters for flushing/cleaning and new oil inlet
Inspection windows	Oil quality visual control
Filter Control	Continuous monitoring of filters and warning of upcoming replacement
Zero-Cross Contamination	Circuit flushing function after each oil type change
Hoses	2 x 3 m (service hoses), 1 x 1.5 m (for waste oil drainage)
BOOST function	Integrated
Service report printing	export via USB to flash drive
Upper grate	Collected oil measurement
Oil pump	2 x 10 l/min hydraulic pumps each; PWM controlled
Languages Menu	15 different languages
Power supply	90/240 VAC, 50-60Hz
SW Update   Service	USB Type A (USB 2.0 flash drive)   USB Type B (direct to PC)
Smartphone App	FluidPRO® ATX Remote Viewer
Dimensions/weight (H X B X T)	120 x 74 x 74 cm, 65 kg



Quick-release couplings: direct connection to the original Mercedes-Benz adapter

ATF Stations	ATX 280	ATX 250	ATX 190
<b>Interchangeable new/spent oil canister:</b>			
Capacity	25 l	25 l	20 l
Weight measurement	-	Scale	Scale
Additive container	500 ml	500 ml	500 ml
Drain grate for gearbox pan	+	+	+
<b>Hydraulic circuit:</b>			
Delivery pump	10 l/min single stage gear	10 l/min single stage gear	10 l/min single stage gear
Boost Pump	10 l/min single stage gear	-	10 l/min single stage gear
Pump displacement	3.6 cm³	3.6 cm³	3.6 cm³
<b>New oil filter:</b>			
Filter	Stainless steel mesh   90 µm	Stainless steel mesh   90 µm	Oil filter MAHLE original OC47 (2 pcs)
<b>Hydraulic Equipment:</b>			
Net length of service hoses 1 and 2	3 m	3 m	3 m
Length of spent oil emptying hose	1.5 m	-	1.5 m
<b>User Interface:</b>			
Display	Touch Screen 7" colors	LCD 4.3"	LCD 4.3"
Keyboard	--	Membrane	Membrane
Software update	Via WiFi connection	USB type A	USB type A
Service	Re.Solve via WiFi	USB type B	USB type B
<b>Functions and Features:</b>			
Fully AutomaticMode	+	+	+
ATFcharge	+	+	+
ATFRecovery	+	+	+
Flushing A/T	+	+	+
Additive Injection	Load Cell	Timed	Load Cell
Zero-Cross ontamination	+	+	+
Emptying of spent ATF tank	Dedicated pipeline with tap	Adapter on tube 1	Dedicated pipeline with tap
Boost function	+	-	+
Web data bank	1st year free	Optional	-
Dipstick function	+	-	+
Thermal printer	Optional	Optional	+
<b>Dimensions:</b>			
LxWxH	740 x 740 x 1200 mm	740 x 740 x 1200 mm	740 x 740 x 1200 mm
Empty weight	approx. 62 kg	approx. 62 kg	approx. 65 kg
<b>Power supply:</b>			
Frequency	50-60 Hz	50-60 Hz	50-60 Hz
Voltage	90/240 VAC	90/240 VAC	90/240 VAC
Power	500 W	500 W	500 W
Thermal switch	12 A	12 A	12 A
<b>Environmental conditions:</b>			
Operating Temperature	5-50 °C	5-50 °C	5-50 °C
Humidity	10-90% RH (non-condensing)	10-90% RH (non-condensing)	10-90% RH (non-condensing)



# MAHLE Adapter Kits

Thanks to the large number of adapters available, 90% of the automatic transmissions on the market is covered. The correct adapter is indicated on the station display, so peace of mind is guaranteed.



## Adapter Kits

Code	Article	Description
included with ATX	ADAPTERS KIT 1-17	Fitting kit (17 fittings) from no. 1 to no. 17
1010320108XX	ADAPTERS KIT 18-33	Fitting kit (16 fittings) from no. 18 to no. 33
1010320106XX	ADAPTERS KIT 34-47	Fitting kit (14 fittings) from no. 34 to no. 47
1010320107XX	ADAPTERS KIT 48-60	Fitting kit (13 fittings) from no. 48 to no. 60



# MAHLE Adapter Kits

## Adapters Kit 1-17

Code	Description	Models	Variants	
-	<b>1</b>	BMW, VOLVO, MERCEDES-BENZ, AUDI, RENAULT, SAAB, FORD	Various Transmission Type	
-	<b>2</b>	BMW, AUDI, RENAULT, SAAB, FORD, RANGE- ROVER, JAGUAR	Various Transmission Type	
-	<b>3</b>	AUDI, VOLKSWAGEN, JEEP	Various Transmission Type	
-	<b>4</b>	OPEL-SUBARU-MAZDA- CITROEN-RENAULT- ALPHA ROMEO-LANCIA	Various Transmission Type	
-	<b>5</b>	AUDI, BMW (8 SPEED), JAGUAR, LAND-ROVER, ALFA ROMEO, JEEP, IVECO	ZF	
-	<b>5A</b>	BMW (8 SPEED) D. 18mm	ZF	
-	<b>6</b>	JEEP, FIAT, CHRYSLER, MERCEDES-BENZ, SUBARU	Various Transmission Type	
-	<b>7</b>	AUDI, MERCEDES-BENZ, MITSUBISHI	Various Transmission Type	
-	<b>8</b>	JAGUAR, MERCEDES- BENZ, SSANGYONG	Various Transmission Type	

## Adapters Kit 1-17

Code	Description	Models	Variants	
-	<b>9</b>	JAGUAR, MERCEDES- BENZ, MITSUBISHI, SSANGYONG	5-SPEED	
-	<b>10</b>	JAGUAR, FORD, MAZDA	5-SPEED	
-	<b>11</b>	VOLKSWAGEN, AUDI, MITSUBISHI	ZF	
-	<b>12</b>	AUDI, VOLKSWAGEN, PORSCHE, LEXUS, MITSUBISHI	AISIN /ZF	
-	<b>13</b>	VOLVO	Various Transmission Type	
-	<b>14</b>	HYUNDAI, TOYOTA, KIA, MITSUBISHI, ISUZU	Various Transmission Type	
-	<b>15</b>	"PIPES FOR GENERAL USE Diameter 10 - 13 - 15mm"	-	
-	<b>16</b>	AUDI, VOLKSWAGEN, SEAT, SKODA	VW DSG	
-	<b>17</b>	JEEP, FIAT, ALFA ROMEO, OPEL, CITROEN	AISIN	

# MAHLE Adapter Kits

## Adapters Kit 18-33

Code	Description	Models	Variants	
1010320023XX	<b>18</b>	RENAULT, MITSUBISHI, NISSAN	Jatco / Multitronic	
1010320024XX	<b>19</b>	FIAT, JEEP, LAND-ROVER	ZF	
1010320025XX	<b>20</b>	TRANSMISSION DIPSTICK FORD, JEEP, DODGE	-	
1010320026XX	<b>21</b>	MERCEDES-BENZ, RENAULT	DSG Mercedes	
1010320027XX	<b>22</b>	FORD, RENAULT, PEUGEOT, VOLVO	POWERSHIFT	
1010320028XX	<b>23</b>	TOYOTA, SUZUKI, MAZDA	CVT	
1010320029XX	<b>24</b>	FIAT, CITROEN, PEUGEOT, RENAULT	4-Speed	
1010320030XX	<b>25</b>	AUDI (Q7/A8), BMW	ZF / CVT	
1010320031XX	<b>26</b>	MITSUBISHI PAJERO	4-Speed	

## Adapters Kit 18-33





Code	Description	Models	Variants	
1010320032XX	<b>27</b>	AUDI	Various Transmission Type	
1010320033XX	<b>28</b>	GM	Various Transmission Type	
1010320034XX	<b>29</b>	JEEP, DODGE, OPEL, GM	4-Speed	
1010320035XX	<b>30</b>	JEEP	5-Speed	
1010320036XX	<b>31</b>	RENAULT	Various Transmission Type	
1010320037XX	<b>32</b>	QUICK COUPLER 90° (2 pcs)	-	
1010320038XX	<b>33</b>	Dipstick for MERCEDES BENZ, CHRYSLER	-	

# MAHLE Adapter Kits

## Adapters Kit 34-47





Code	Description	Models	Variants	
1010320054XX	34	JEEP, MITSUBISHI, MERCEDES GLK, GM, SUZUKI, TOYOTA	Various Transmission Type	
1010320055XX	35	VOLVO XC60, V60	AISIN	
1010320056XX	36	MERCEDES-BENZ CLK, C, AMG	5-Speed	
1010320057XX	37	CITROEN, PEUGEOT	Various Transmission Type	
1010320058XX	38	GM, FIAT, FORD, JEEP, CHRYSLER VOYAGER, SAAB, MERCEDES ML	Various Transmission Type	
1010320059XX	39	BMW-JAGUAR	Various Transmission Type	
1010320060XX	40	GM, DODGE RAM	Various Transmission Type	
1010320061XX	41	PEUGEOT, CITROEN, VW, FIAT DUCATO	ZF	
1010320062XX	42	VOLVO, MINI, BMW	AISIN	







## Adapters Kit 34-47

Code	Description	Models	Variants	
1010320073XX	43	VOLVO	AISIN	
1010320082XX	44	MERCEDES, JEEP, FIAT	9 Gtronic	
1010320089XX	45	PEUGEOT, CITROEN	AISIN	
1010320090XX	46	BMW X1	Various Transmission Type	
1010320091XX	47	MERCEDES level tool	9 Gtronic	



# MAHLE Adapter Kits

Adapters Kit 48-60				
Code	Description	Models	Variants	
1010320092XX	48	PEUGEOT	AISIN	
1010320093XX	49	JEEP FREEMONT	Various Transmission Type	
1010320094XX	50	RENAULT LAGUNA III, ESPACE IV	Various Transmission Type	
1010320095XX	51	AUDI	CVT	
1010320096XX	52	AUDI A8	ZF	
1010320097XX	53	AUDI	DSG 7-Speed	
1010320098XX	54	MAZDA	6-Speed	
1010320099XX	55	NISSAN JUKE (2011 - 2014)	CVT	
1010320100XX	56	NISSAN JUKE (2014 - 2019)	CVT	

Adapters Kit 48-60				
Code	Description	Models	Variants	
1010320101XX	57	FIAT-CITROEN- PEUGEOT	AISIN	
1010320102XX	58	LAND ROVER-VOLVO	ZF	
1010320103XX	59	PEUGEOT-BMW-MINI	Various Transmission Type	
1010320104XX	60	PEUGEOT-VOLVO	AISIN	
Other Adapters				
1010320105XX	61	MERCEDES	ZF	
1010320112XX	62	FIAT-CITROEN- SAAB- VOLVO	AISIN	
1010320113XX	63	VARIOUS ADAPTER	Various Transmission Type	
1010320114XX	64	MERCEDES	7-Speed	
1010320115XX	65	AUDI-VOLKSWAGEN	Various Transmission Type	



# Long live the gearbox

## The importance of completing the service with the replacement of the filter

Like all consumables in a vehicle, transmission oil is subject to aging and wear. At very high temperatures, e.g. in sports driving or in vehicles with trailers, the oil in the automatic transmission can age faster than normal. To ensure that increasingly complex automatic transmissions last a long time and run smoothly, many vehicle manufacturers are changing their gearbox oil requirements from filling for the entire service life to replacing the oil periodically or as needed.



## Simply better: dynamic oil change

The traditional, i.e. static, method involves replacing about 30-50% of the oil, which means that the new oil mixes with the old oil. Dynamic oil changes, performed with MAHLE ATX 250/280 rinsers, on the other hand, allow up to 100% of the oil to be changed.

## Comparison of oil change methods

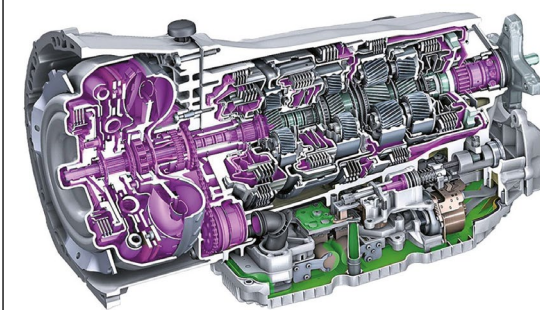

■ Static oil change    ■+ Dynamic oil change

## Driver benefits:

- Avoid gearbox repair costs
- Significantly easier gear shifts
- Elimination of minor gearbox problems (e.g. jerking or malfunctioning at the start)
- Higher gearbox mileage



Almost 90% of all automatic transmissions on the market are compatible with MAHLE ATX 250/280. Dynamic oil change allows for 90 to 100% oil change.

Currently 25% of newly registered vehicles in the EU are equipped with automatic transmissions and the trend is increasing. Changing the transmission oil every 60,000 km or every 4 years will extend the life of complex automatic transmissions and ensure their optimal operation.





# Overview of the transmission oil filter program

Code	Brand	Model:	Available
HX 46	Mercedes-Benz	124 Saloon (W124), 190 (W201), C-Class (W202)	x
HX 46D1	Mercedes-Benz	124 Saloon (W124), 190 (W201), C-Class (W202)	x
HX 46D2	Mercedes-Benz	124 Saloon (W124), 190 (W201), C-Class (W202)	x
HX 48	Mercedes-Benz	E-Class (W124), E-Class (W210), SL (R129)	x
HX 81D	Mercedes-Benz	E-Class (W202), C-Class (W203), Sprinter van 3.5 t (B906)	x
HX 82D	Volkswagen	Golf II (19E, 1G1), Jetta II (19E, 1G2, 165), Transporter IV Platform/Chassis (70E, 70L, 70M, 7DE, 7DL, 7D)	x
HX 84D	Audi/Volkswagen	A4 (B6) Avant (8E5), Passat B5.5 (3B3), Passat B5.5 Variant (3B6)	x
HX 85D	Audi	100 (C4) Saloon (4A2), A6 (C4) (4A2), A6 (C4) Avant (4A5)	x
HX 87D	BMW	5 Series (E34), 7 Series (E32), 8 Series (E31)	x
HX 88D	BMW	3 Series (E30), 3 Series (E36), 5 Series (E34)	x
HX 124D	Mercedes-Benz	C-Class (W203), C-Class (W205), Sprinter van 3.5 t (B906)	x
HX 132D	Volkswagen	Golf V (1K1), Passat B8 Variant (3G5, CB5), Touran (1T1, 1T2)	x
HX 139D	Volkswagen	Tiguan (5N), Tiguan (AD1, AX1), Transporter V Bus (7HB, 7HJ, 7EB, 7EJ, 7EF, 7EG, 7HF, 7EC)	x
HX 147KIT	Seat/Volkswagen	Ibiza III (6L1), Golf IV (1J1), Polo (6N2)	x
HX 147KIT1	Seat/Škoda/Volkswagen	Ibiza II (6K1), Octavia I (1U2), Golf IV (1J1)	x
HX 148D	Citroën/Peugeot	C3 I (FC, FN), 206 Hatchback (2A/C), 208 I (CA, CC)	x
HX 149D	Ford	Fiesta VI (CB1, CCN), Focus I (DAW, DBW), Focus II (DA, HCP, DP)	x
HX 150KIT	Volkswagen	Golf V (1K1), Polo (9N), Touran (1T1, 1T2)	x
HX 151KIT	Ford/Renault	Focus II (DA, HCP, DP), Focus II Saloon (DB, FCH, DH), Kadjar (HA, HL)	x
HX 152	BMW Alpina	b3 (E90), B5	x
HX 153D	Ford	Focus II (DA, HCP, DP), Focus II Saloon (DB, FCH, DH), Focus II Turnier (DA, FFS, DS)	x
HX 154	BMW	1 Series (E87), 3 Series (E90)	x
HX 155	Audi	A4 (B8) (8K2), A4 (B8) Avant (8K5), A6 (C7) (4G2, 4GC)	x
HX 156	Hyundai/Kia	ix35 (LM, EL, ELH), Tucson (JM), Sportage III (SL)	x
HX 157D	Opel	Astra H (A04), Corsa C (X01), Corsa D (S07)	x
HX 158D	Mercedes-Benz	A-Class (W169), B-Class Sports Tourer (W245)	x
HX 159KIT	BMW	3 Series (E46), X3 (E83), Z3 Roadster (E36)	x
HX 160KIT	Audi/Porsche/Volkswagen	Q7 (4LB), Cayenne (9PA), Touareg (7LA, 7L6, 7L7)	x
HX 162D	BMW	7 Series (E65, E66, E67), X3 (E83), X5 (E53)	x
HX 163KIT	BMW	3 Series (E36), 5 Series (E39), X5 (E53)	x
HX 164D	Audi	A6 (C6) (4F2), A6 (C6) Avant (4F5), A8 (D3) (4E2, 4E8)	x
HX 164D1	Audi	A6 (C6) (4F2), A6 (C6) Avant (4F5), A8 (D3) (4E2, 4E8)	x
HX 165KIT	BMW	3 Series (E46), 5 Series (E39), X3 (E83)	x

Code	Brand	Model:	Available
HX 166D	Opel	Astra G Hatchback (T98), Vectra B (J96), Zafira A MPV (T98)	x
HX 167D	audi/Seat	A4 (B7) Avant (8ED), A6 (C6) Avant (4F5), Exeo ST (3R5)	x
HX 168D	Audi	A4 (B6) Convertible (8H7), A6 (C5) (4B2), A6 (C5) Avant (4B5)	x
HX 169KIT	Mini	Clubman (R55), Countryman (R60), Mini (R56)	x
HX 184 KIT	BMW	1 Series (F20), 2 Series (F45), Z4 (E89)	x
HX 185D	Audi/Porsche	A6 (C7) Avant (4GS, 4GD), Q5 (8RB), Macan (95B)	x
HX 186D	Audi/Porsche	A6 (C7) Avant (4GS, 4GD), Q5 (8RB), Macan (95B)	x
HX 187KIT	Audi/Porsche/Volkswagen	Q7 (4LB), Panamera (970), Touareg (7P5, 7P6)	x
HX 188	Opel/Renault/Volvo	Vectra C (Z02), Espace IV (JK0/1), V70 II (285)	x
HX 189KIT	Audi	A6 (C7) Avant (4G5, 4GD), A7 Sportback (4GA, 4GF), Q5 (8RB)	x
HX 192D	Audi	A4 (B8) Avant (8K5), A5 Sportback (8TA), A6 (C7) (4G2, 4GC)	x
HX 193D	Mazda	3 (BM, BN), CX-3 (DK), CX-5 (KF)	x

Code	Brand	Model:	Available
HX 158D1	Mercedes-Benz	A-Class (W169), B-Class Sports Tourer (W245)	x
HX 161D	Mercedes-Benz	A-Class (W176), B-Class Sports Tourer (W246), GLA-Class (X156)	x
HX 190D	Audi/Škoda/Volkswagen	A3 Sportback (8VA, 8VF), Octavia II Combi (5E5, 5E6), Passat B8 Variant (3G5, CB5)	x
HX 191	Škoda/Volkswagen	Yeti (5L), Polo V (6R1, 6C1)	x
HX 196 KIT	Mercedes-Benz	C-Class, GLC-Class, S-Class	x
HX 230 KIT	Mercedes-Benz	C-Class (W205), GLK-Class (X204), M-Class (W164)	x
HX 232 D	Mercedes-Benz	A-Class (W176), B-Class Sports Tourer (W246), GLA-Class (X156)	x
HX 233D	Audi	A4 (B8) (8K2), A4 (B8) Avant (8K5), A5 (8T3)	x
HX 234D	Toyota	Camry Saloon (V5), RAV4 IV (A4)	x
HX 235D	Audi	A6 (C6) (4F2), A6 (C6) Avant (4F5), A8 (D3) (4E2, 4E8)	x
HX 235D1	Audi	A6 (C6) (4F2), A6 (C6) Avant (4F5), A8 (D3) (4E2, 4E8)	x
HX 236D	Volkswagen	passat CC (B6) (357), Tiguan (5N_)	x
HX 237D	Lexus/Toyota	RX (_U3_), Avenis Estate (_T25_), Camry Saloon (_V4_)	x
HX 238D	Citroën/Peugeot	C5 I (DC_), 407 (6D_), 407 SW (6E_)	x
HX 239D	BMW	5 Series (E39), 3 Series (E46)	x
HX 240D	BMW	1 Series (E87), 3 Series (E90), X1 (E84)	x
HX 244	Hyundai/Kia	Accent IV Saloon (RB), i20 I (PB, PBT), Rio III Saloon (UB)	x
HX 246D	Hyundai/Kia	Accent III Saloon (MC), Getz (TB), Rio II (JB)	x
HX 254D	Hyundai/Kia	accent IV Saloon (RB), Tucson (TL, TLE), Rio III Saloon (UB)	x
HX 255	Audi/Volkswagen	Q5(FYB, FYG), Q7(4MB, 4MG), Touareg(CR7)	x
HX 256D	Škoda/Volkswagen	Octavia II (1Z3), Golf V (1K1), Touran (1T1, 1T2)	x
HX 258D	Audi	A4 (B9) Avant (8W5, 8WD), A6 (C7) Avant (4G5, 4GD), Q5 (8RB)	x

\* Last update: December 2021.





**MAHLE**

FluidPRO®

ATX 280

