

HIGH VOLTAGE BATTERY SYSTEM EDUCATIONAL TRAINER

Tasks for students

HYBBAT02

www.autoedu.com





CONTENT

1. Safety requirements.....	4
1.1. General safety requirements	4
1.2. Safety requirements for working with electric and hybrid car training equipment.....	6
2. General information.....	10
3. Educational equipment.....	11
4. Practical tasks	13
Practical task No. 1.....	13
Practical task No. 2.....	17
Practical task No. 3.....	19
Contacts	21



1. SAFETY REQUIREMENTS

1.1. General safety requirements

Attention:

Before using the training board, take a look at the user manual.

Training equipment may only be used for the purpose of teaching the design, construction and operating principle of the vehicle.

The staff conducting the training (lecturer, teacher, instructor and others) must be familiar with the instructions for the training equipment, know the methods and principles of use, settings, control of the equipment, be able to switch off (stop) the training equipment in an emergency.

The training staff (lecturer, teacher, instructor and others) acquaint those working and learning with the training equipment with the work safety requirements.

When working with high voltage systems (hybrid power plants and electric vehicles), it is mandatory to comply with electrical safety requirements and use personal protective equipment against electric shock.

It is forbidden to work with educational equipment for children, unqualified staff.

It is forbidden to work with training equipment for persons under the influence of alcohol or other psychotropic substances. Failure to comply with the requirements of this clause will void the warranty and the manufacturer is not liable for any damage or personal injury.

It is forbidden for people who do not have the appropriate qualifications to open the electrical input boxes, connect or change anything there.

It is prohibited to improve, modify or otherwise change the design of training equipment without the written consent of the manufacturer.

Do not ignore the information on possible dangers provided by the warning signs on the training equipment. Beware of the hazards indicated on the warning signs.

The training equipment must be switched off completely during cleaning work.



It is forbidden to wash the training equipment with running water or any chemical cleaning agents.

It is forbidden to clean the electronic components of the training equipment with damp cloths.

The equipment must be completely switched off during maintenance and repair work on the training equipment.

It is forbidden to disconnect the power cords of the electrical elements of the training equipment. Careless or repeated disconnection of these wires will result in damage to the connectors and loss of contact. The desired electrical measurements can be performed at specially designed and installed banana-type connectors in the training equipment. Banana type connectors are resistant to multiple joints.

Before working with training equipment, check that:

- Equipment is not mechanically damaged, broken;
- All protective shields are assembled;
- All components are available;
- The equipment components are free of foreign bodies;
- Undamaged power cords;
- Neat power supplies (battery or stand power supply);
- Power supplies are properly connected (e.g., battery terminals are screwed on, polarity is not mixed, proper power supply is used according to local electrical installation standards);
- The training equipment is properly constructed and locked (e.g., the equipment is placed on a sufficiently solid base,);
- During operation, the equipment will not pose any danger to those working with it and the surrounding staff;
- There are other factors not specified in the instructions that may endanger the health of personnel working with the equipment and others.

Observe during work with the equipment:

- The noise emitted by the equipment is characteristic of such a work process (no extraneous sounds);
- Odour of glowing, burning objects;
- Power supplies are working properly;
- There are no factors or processes other than those specified in the instructions that could endanger the health of personnel working with the equipment or other persons.



1.2. Safety requirements for working with electric and hybrid car training equipment

Employees, lecturers, students, support and service personnel must be familiar with the requirements of the work instructions for work with electrical devices after listening to the instructions and must sign the work safety logs. Instruction of employees and other personnel is carried out in accordance with the normative legal acts, laws and by-laws in force in that state (country). The "Safety Regulations for the Operation of Electrical Equipment" are followed.

Only qualified persons may work with high-voltage components and circuits of electric vehicles (refer to the laws and regulations of your country).

Elements marked in orange (wires, connectors, control units, voltage converters, etc.) are constantly or periodically exposed to high voltages.

Follow the rules for safe work when operating stands.

Warning:

- Before inspecting or servicing the circuits and components of the high voltage system, be sure to remove the maintenance connector (Service plug (fuse)) from the socket in the battery box of the high voltage battery (HV battery). This will turn off the high voltage circuit.
- Place the maintenance connection (Service plug (fuse)) safely out of the reach of other persons to prevent it from being accidentally connected by another person during maintenance and service work.
- Before working on high voltage components, take care of personal protective equipment and equipment: gloves, shoes, face shield, rubber mat, earthing circuit, etc.
- Take care of the safety of the work area around the high-voltage battery: the work area must be marked, a responsible employee must be appointed, and the work area must be fenced. When work is not in progress, high-voltage parts and components must be covered with insulating covers or shields to prevent them from touching them.

CAUTION: HIGH VOLTAGE. DO NOT TOUCH DURING OPERATION.

To draw the attention of other employees, set up an information warning sign.



OPERATION
NOT TOUCH DURING
HIGH VOLTAGE. DO
CAUTION:

CAUTION:
HIGH VOLTAGE. DO
NOT TOUCH DURING
OPERATION



The table must be printed, folded into a triangle (the bends are marked with a dotted line) and placed on the car.

Hybrid cars may not make any noise. The absence of noise does not mean that the car is switched off.

Always disconnect the negative terminal of the 12 V battery if necessary.

High voltage battery, connected with high voltage (marked in orange) wires to voltage converter, electric motor / generator, air conditioner pump. High voltage wires, regardless of their polarity, have orange insulation.

The high voltage battery is protected by a fuse. Voltage switching on and off is control

Attention:

There may be residual voltage in the high voltage circuit after it has been switched off. Therefore, wait at least 10 minutes after switching off the system. During this time, it is forbidden to touch, disconnect, repair or inspect high-voltage wires.

Both positive and negative high voltage wires are separated from the car body. Therefore, there is no possibility of electric shock when touching the metal parts of the car.

When working with high voltage components, the battery must use protective equipment:

- glasses
- face shield
- rubber, latex gloves;
- protective clothing and apron;
- rubber boots:
- rubber mats.

All protective and working equipment must meet the requirements of electrical safety standards, be metrologically inspected and have valid metrological inspection documents.

When preparing to work with a hybrid / electric car, it is necessary to turn off the car by removing the negative terminal of the car's 12 V battery. Wait 2 minutes. Using protective equipment (gloves, work clothes, shoes, goggles, mats, etc.) disconnect the high voltage service connector (Service plug (fuse)): unlock the lever lock, lift the lever up and pull the entire service connector out of the socket.

When disconnecting high voltage cables, they must be insulated. This avoids short circuits, self-coupling and human protection. Use only fully insulated tools for this purpose.

After disconnecting the electrical components, make sure that there is no residual voltage.



Protective equipment must be used when working with high voltage circuits. Measure the voltage inside the electrical components before working on them. The devices must display 0 V. It is only possible to work with high-voltage circuit elements at least 10 minutes after the circuit has been switched off. There are capacitors in the system that need to be discharged (discharged).

Attention!

Work safety instructions must be observed when working with high voltage circuits. Workers working on high-voltage circuits can be shocked by high-voltage electricity and injured by improper handling of measuring and repair equipment due to sparks. At the beginning of the work, it must be ensured that all repair and maintenance work is carried out only with the high-voltage lines disconnected.



2. GENERAL INFORMATION

Training equipment parameters

Length	720 mm (28.346 in);
Width	310 mm (12.205 in);
Height	705 mm (27.75 in);
Weight about	20 kg (44.092 lb);
Energy sources	battery 12 V or household electrical network ~ 230 / 110 V AC 50 / 60 Hz

Educational equipment is made using elements of the car:

Manufacturer:	Toyota
Model:	Prius II
Year of production:	2009 – 2015
	high voltage battery pack 201,6 V DC

WARNING:

Personal protective equipment must always be used when removing and installing the service plug.

3. EDUCATIONAL EQUIPMENT

A general view and structure of the training equipment is presented in the illustrations below.

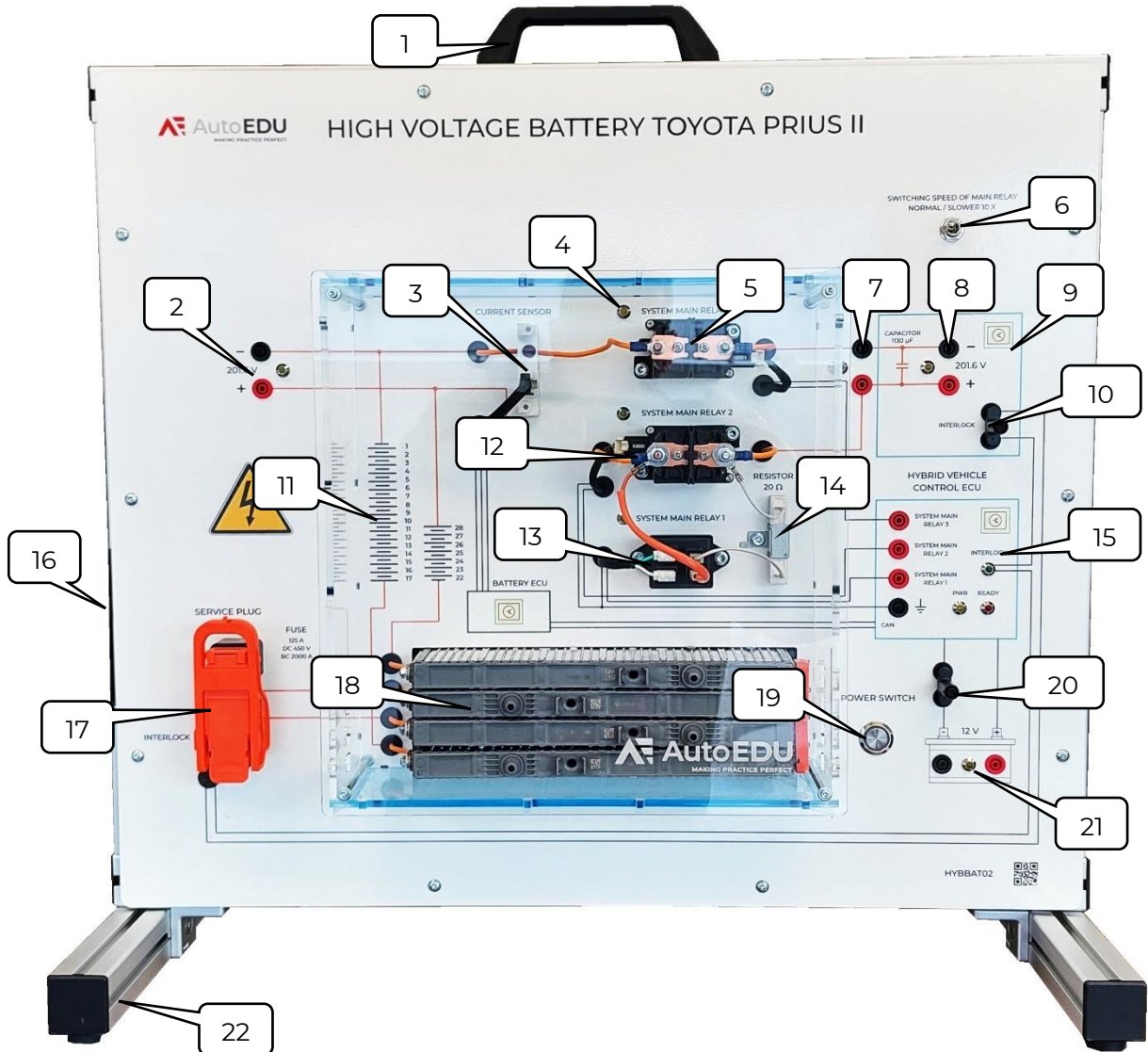

1. Transport handle
2. High voltage battery voltage measurement points
3. Current sensor
4. LED indicator
5. System main relay 3 (-)
6. Relay activation speed reduction switch
7. High voltage battery voltage measurement points (when the relays are on)
8. Voltage measurement points in the inverter (and capacitor)
9. Inverter



10. Inverter interlock (jumper)
11. High voltage battery modules (drawing)
12. System main relay 2 (+)
13. System main relay 1
14. System main resistor
15. Hybrid vehicle control ECU
16. Power supply connector
17. Service plug (and interlock)
18. High voltage battery modules
19. Power switch
20. 12 V battery disconnect terminal
21. 12 V battery
22. Stand legs

Note:

If you need to lay the stand horizontally on a table, remove the legs.

4. PRACTICAL TASKS

Practical task No.1

Service plug removal

1. Familiarize yourself with the training equipment - high voltage battery pack.
2. Correctly remove the service plug from the socket according to Toyota safety requirements.

Steps to remove the service key plug

ATTENTION

Always wear insulating gloves and safety glasses when working with high-voltage systems.

Check that the protective gloves are not damaged.

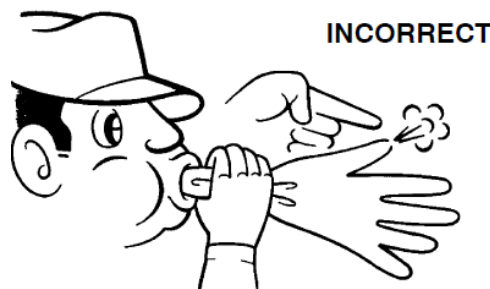

Keep the removed service plug in your pocket to prevent other technicians from reconnecting it while you are servicing the vehicle.

After removing the service plug grip, do not touch the high voltage connectors and terminals for 10 minutes.

NOTICE:

After removing the service plug grip, do not operate the power switch as it may damage the hybrid vehicle control ECU (valid in a real car).

Before removing the service plug, it is necessary to turn off the hybrid vehicle by pressing the POWER SWITCH. READY should go out on the instrument panel.

Note:

The equivalent of the READY inscription on the instrument panel is an LED (READY) installed in the hybrid car's control ECU.



Wait 2 minutes.

Disconnect the negative terminal of the 12 V batteries.

Remove the service plug.

When removing the service plug, its handle is first lifted upwards, then swung back from the stand and pulled out of the socket.

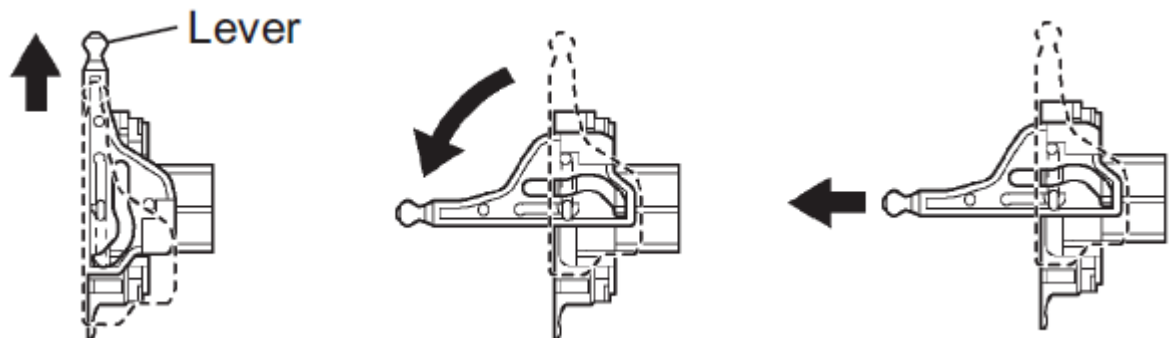

Wait 10 minutes.

After removing the service plug only after 10 min. it is possible to start work with high-voltage electrical circuits. This time is required to discharge the high voltage capacitors.

Below is the sequence of service plug connection law.

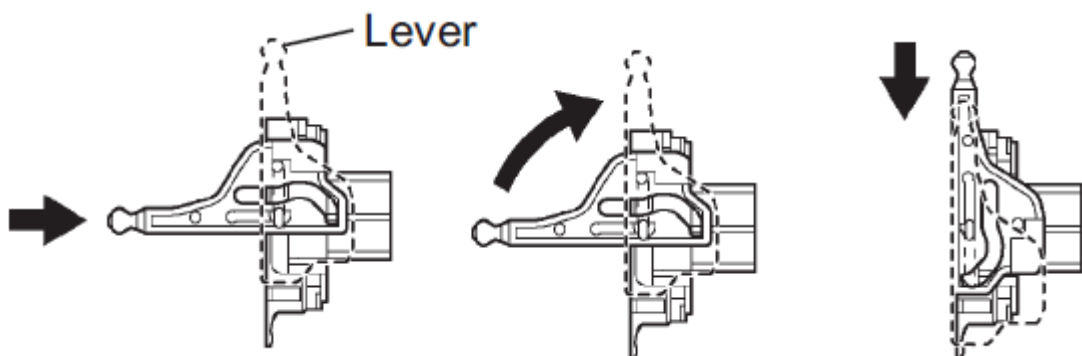

Inserting the service plug into the socket

Connect the negative terminal of the 12 V batteries.

Turn on the stand by pressing the POWER SWITCH. READY should go out on the instrument panel.

Note:

The equivalent of the READY inscription on the instrument panel is an LED (READY) installed in the hybrid car's control ECU.



Toyota safety instructions

PRECAUTIONS FOR HIGH VOLTAGE CIRCUIT INSPECTION AND SERVICE

(a) Engineer must undergo special training to be able to perform high voltage system inspection and servicing.

(b) All high voltage wire harness connectors are colored orange. The HV battery and other high voltage components have “High Voltage” caution labels. Do not carelessly touch these wires and components

(c) Before inspecting or servicing the high voltage system, be sure to follow safety measures, such as wearing insulated gloves and removing the service plug to prevent electrocution. Carry the removed service plug in your pocket to prevent other technicians from reinstalling it while you are the servicing vehicle.

(d) After removing the service plug, wait 10 minutes before touching any of the high voltage connectors and terminals.

HINT:

10 minutes are required to discharge the high voltage condenser inside the inverter.

(e) Be sure to install the service plug before starting the hybrid system. Starting the hybrid system with the service plug removed may damage the vehicle.

(f) Before wearing insulated gloves, make sure that they are not cracked, ruptured, torn, or damaged in any way. Do not wear wet insulated gloves.

(g) When servicing the vehicle, do not carry metal objects like mechanical pencils or scales that can be dropped accidentally and cause a short circuit.

(h) Before touching a bare high voltage terminal, wear insulated gloves and use an electrical tester to ensure that the terminal is not charged with electricity (approximately 0 V).

(i) After disconnecting or exposing a high voltage connector or terminal, insulate it immediately using insulation tape.

(j) The screw of a high voltage terminal should be tightened firmly to the specified torque. Both insufficient and excessive torque can cause failure.

(k) Use the “CAUTION: HIGH VOLTAGE. DO NOT TOUCH DURING OPERATION” sign to notify other engineers that a high voltage system is being inspected and/or repaired.

(l) Do not place the battery upside down while removing and installing it.

(m) After servicing the high voltage system and before reinstalling the service plug, check again that you have not left a part or tool inside, that the high voltage terminal screws are firmly tightened, and that the connectors are correctly connected.



PRECAUTIONS FOR INSPECTING HYBRID BATTERY SYSTEM

(a) Before inspecting the high-voltage system, take safety precautions to prevent electrical shocks, such as wearing insulated gloves and removing the service plug grip. After removing the service plug grip, put it in your pocket to prevent other technicians from reconnecting it while you are servicing the high-voltage system.

NOTICE:

Turning the power switch ON (READY) with the service plug grip removed could cause a malfunction. Therefore, do not turn the power switch ON (READY) unless instructed by the repair manual.

(b) After disconnecting the service plug grip, wait for at least 10 minutes before touching any of the high voltage connectors or terminals.

HINT:

At least 10 minutes are required to discharge the high-voltage condenser inside the inverter.

(c) Since liquid leakage may occur, wear protective goggles when checking inside the HV battery.

(d) Wear insulated gloves, turn the power switch OFF, and disconnect the negative terminal of the auxiliary battery before touching any of the orange-colored wires of the high-voltage system.

(e) Turn the power switch OFF before performing a resistance check.

(f) Turn the power switch OFF before disconnecting or reconnecting any connector.

(g) To install the service plug grip, the lever must be flipped and locked downward. Once it is locked in place, it turns the interlock switch ON. Make sure to lock it securely because if you leave it unlocked, the system will output a DTC related to the interlock switch system.



A short pin for the interlock switch is provided on the service plug grip and the inverter cover. Therefore, the interlock signal line circuit opens when the service plug grip or the inverter cover is removed.



Resistance: _____

Practical task No. 3

High voltage battery voltage measurement

1. Familiarize yourself with the training equipment - high voltage battery pack.
2. Measure the total voltage (V) of the entire battery.

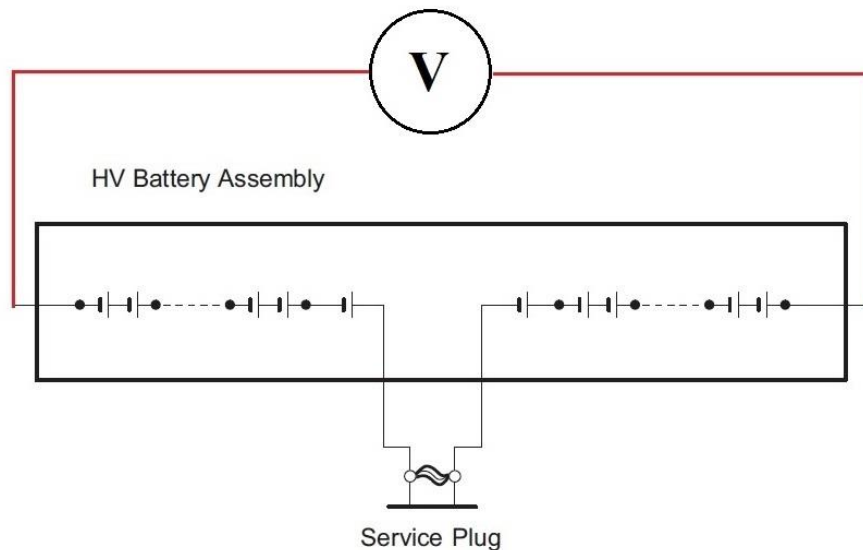

Total voltage (V) of the entire battery: _____ V.

3. Correctly remove the service plug from the socket according to Toyota safety requirements.
4. Measure the voltages of the separated batteries of the service plug.

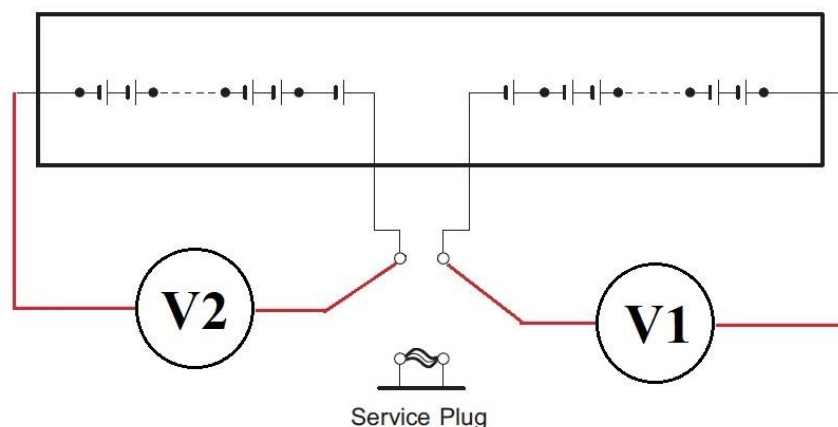

Voltage (V1) of the battery: _____ V.

Voltage (V2) of the battery: _____ V.



5. Measure the voltage of one module of the battery.

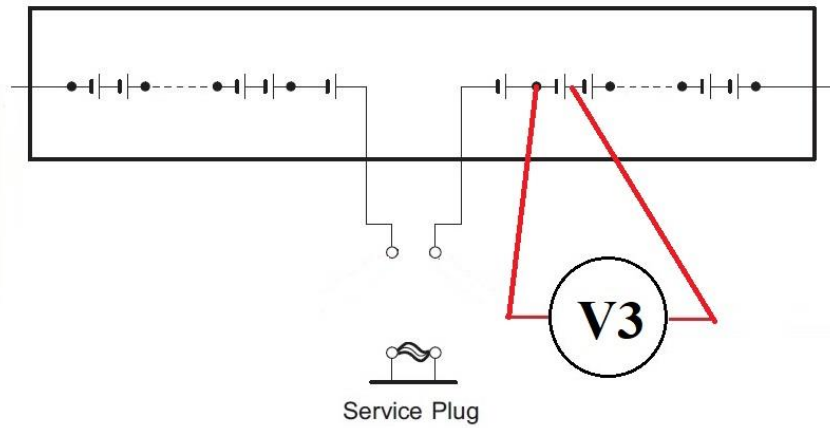

Voltage (V3) of the battery: _____ V.



CONTACTS

Auto EDU, UAB

Ateities str. 30 G, Kaunas,
LT – 52163, Lithuania

Tel.: +370 – 37 337842

Fax: +370 – 37 337842

Email: info@autoedu.lt

www.autoedu.com