

## WHEEL BEARING REMOVAL & INSTALLATION KIT

VT01717K

### Information

The vehicles mentioned in the list are equipped with rear wheel bearings from the factory, featuring a GEN2 design wheel bearing that lacks a central hole, which can pose difficulties during removal. In contrast, replacement bearings come with a central hole, facilitating the use of a central force screw for installation.

As it is a GEN2 design, it is imperative to install the bearing by applying pressure solely to the outer bearing race. To address this, a specialized kit has been meticulously made to not only remove the original bearing but also seamlessly install the new bearing using a force screw, simplifying the replacement process on the vehicle.

It is essential to remember to lubricate the force screw with Molybdenum Disulphide grease at all times.

### Safety First

- Only operate if trained to do so.
- Read these instructions carefully and retain for future reference.
- Ensure the vehicle is properly supported with the wheels secured, in line with manufacturer's guidelines.
- Wear safety apparel while operating and keep hands away from moving parts.



## Applications

The kit simplifies bearing replacement on models with the GEN2 no center hole bearing:

Citroen	Jumpy/Space Tourer	>2016
Peugeot	Traveller/Expert	>2016
Toyota	Proace/Proace Verso	>2016
Vauxhall/Opel	Vivaro	>2019

## Safety Guidelines

- Carefully read and follow all instructions provided with the kit. Make sure you understand each step before proceeding.
  - Wear appropriate protective equipment such as safety goggles, gloves, and steel-toe boots. This can help prevent injury if tools slip or parts break.
  - Use jack stands and wheel chocks to properly secure the vehicle before working underneath. Do not rely solely on a jack to support the vehicle weight.
  - Make sure the vehicle is turned off and unable to roll as you work. Engage the parking brake.
  - Avoid distractions and give the job your full attention. Rushing increases the risk of mistakes.
  - Use properly sized tools for the job that are in good condition. Avoid improvising with the wrong tools.
- Follow torque specifications provided for reinstalling parts. Use a calibrated torque wrench.
- Clean all parts thoroughly before reassembly. Dirt and debris can hamper smooth operation.
  - Double check all fasteners are tightened to spec once the job is complete. Do a test drive before releasing the vehicle.
  - Dispose of old bearings, used tools and equipment properly.



## Disposal

Used bearings should be thoroughly cleaned and separated into component materials—steel, rubber, plastic—for recycling. Metals can often be recycled if free of grease. Plastics may also be recyclable when cleaned. Rubber and lubricants require proper hazardous waste disposal. Consult local environmental regulations and automotive parts vendors for guidance on responsible recycling options or trade-in programs.





**Safety Precautions for Molybdenum Disulphide Grease**

Wear proper PPE - Use protective gloves, goggles, and clothing to avoid skin and eye contact. Moly grease can be irritating.

Avoid breathing dust - When handling the grease, minimize dust inhalation which can cause respiratory irritation. Use in well ventilated areas.

Wash hands thoroughly after handling - After contact with moly grease, wash hands with soap and water to remove residue.

Keep away from ignition sources - Moly grease is flammable. Keep away from sparks, open flames, or other heat sources.

Store securely - Keep moly grease tightly sealed in approved containers and stored in cool, dry places away from incompatible materials.

Use proper disposal - Dispose of used moly grease responsibly according to local environmental regulations. Do not drain into sewers.

Lubricate as directed - Only apply molybdenum disulphide grease onto parts and surfaces as specified in equipment manuals and instructions.



REF. NUMBER	DESCRIPTION	SPARE PART No.	REF. NUMBER	DESCRIPTION	SPARE PART No.
1	FORCE SCREW		9	HUB CLAM SHELL, EXTRACTION x2	
2	SUPPORT RODS x3		10	NUTS(?) x6	
3	REACTION PLATE, EXTRACTION		11	PUSH PINS x3	
4	PULLER DISC, INSERTION		12	SCREWS FOR D&H x4	
5	EXTRACTION/INSERTION PLATE		13	SPACER	
6	FORCE SCREW		14	WASHERS x6	
7	HUB ADAPTOR BOLTS x3		15	MOLYBDENUM DISULPHIDE GREASE	
8	BEARING CLAM SHELL, INSERTION x2				

## Instructions

- Safely lift the vehicle and support it on jack stands with the wheels suspended. Make sure the vehicle is properly secured.
- Take off the rear wheels.
- Detach the brake caliper, rotor, and dust shield from the wheel hub area. Refer to vehicle service manual for proper removal method.

**Important:** Do not use impact tools in conjunction with this bearing removal and installation kit. Use only hand tools as instructed. Impact tools may cause damage.

### BEARING EXTRACTION

FIG1

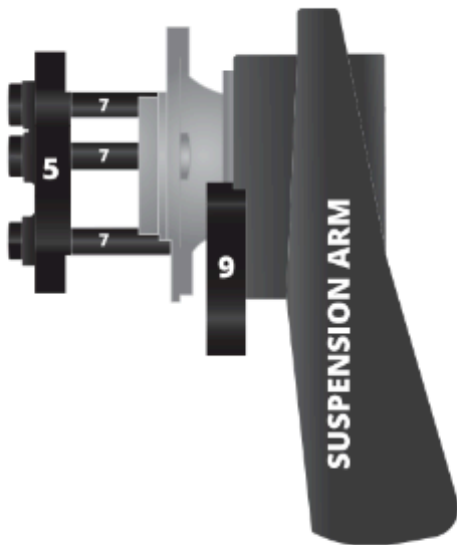

FIG2

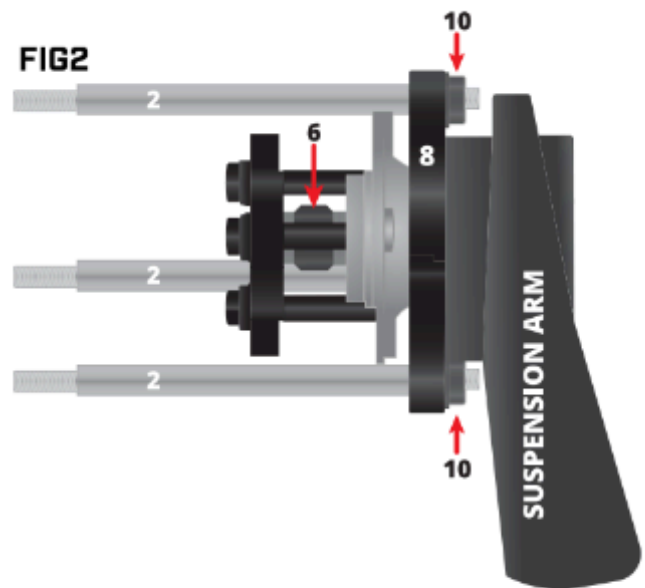

FIG3

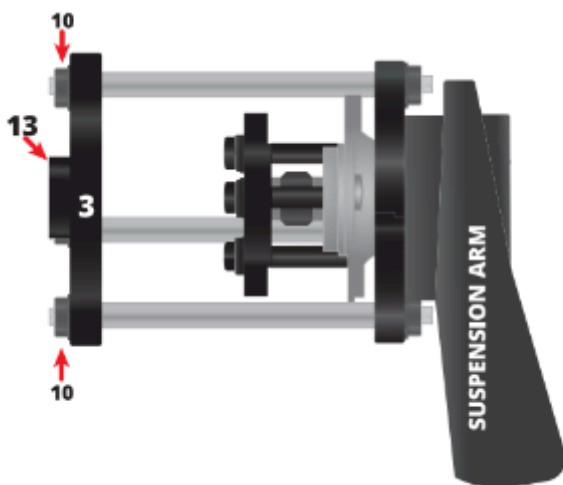
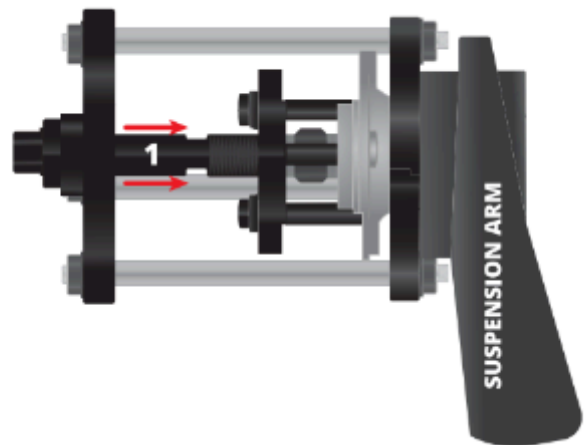
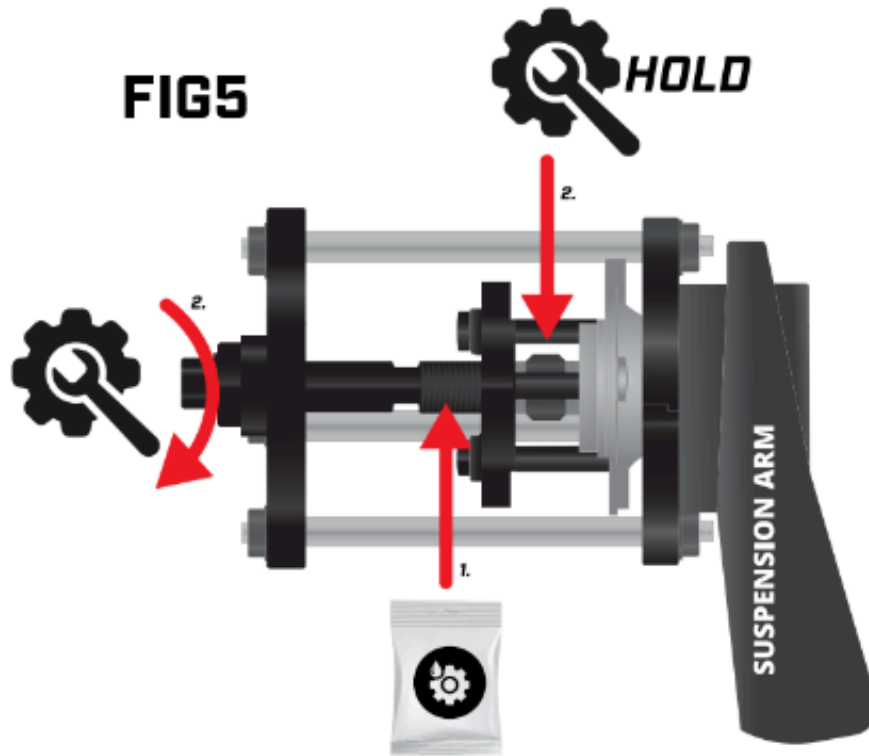

FIG4





- Refer to Figures 1, 2, 3, 4 and 5 to assemble the bearing extractor tool. Make sure part (5) is positioned parallel to the wheel hub flange during assembly, as shown.
- Lubricate the force screw and nut (1) with molybdenum disulfide grease. Ensure they are clean and well lubricated.
- Mount the assembled extractor onto the wheel hub over the bearing.
- Hold nut (1) in place using an appropriate wrench or locking pliers.
- Turn the force screw clockwise using a suitable wrench or ratchet driver. Apply steady pressure.
- As the force screw is tightened, it will begin pulling the bearing out of the wheel hub.
- Continue turning the force screw until the bearing is completely extracted from the hub.
- Once fully removed, disassemble the extractor and remove the old bearing from the tool.
- Clean the hub surface and inspect it for any damage.

## Instructions

---

### BEARING INSERTION

**FIG6**

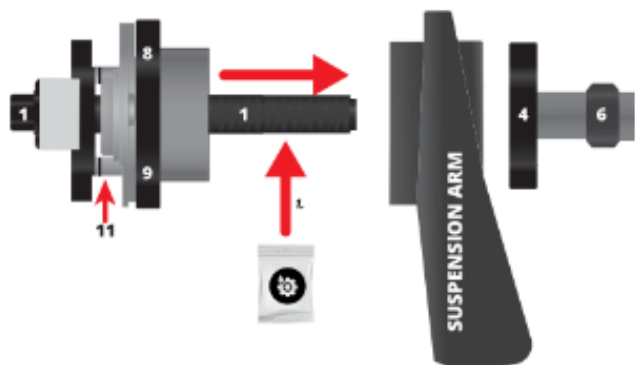

- Refer to Figure 6 for proper assembly of the bearing insertion components.
- Position the bearing clamp shells (9) around the outer race of the new bearing.
- Lubricate the force screw (1) with molybdenum disulfide grease, ensuring it is clean.
- Mount the assembled inserter onto the wheel hub and align it flush with the hub surface.
- Hold the force screw nut in place using an appropriate wrench or locking pliers.

- Turn the force screw clockwise using a suitable wrench or ratchet driver. Apply steady pressure.

- Keep the insertion assembly centered and aligned to the hub as shown in Figure 7 during the process.

- As the force screw tightens, it will begin pushing the new bearing into the wheel hub.

- Continue turning the force screw until the bearing is fully seated in the hub.

- Once inserted, disassemble the insertion components and remove them from the hub.

- Perform a final check that the new bearing is properly aligned and fully seated.

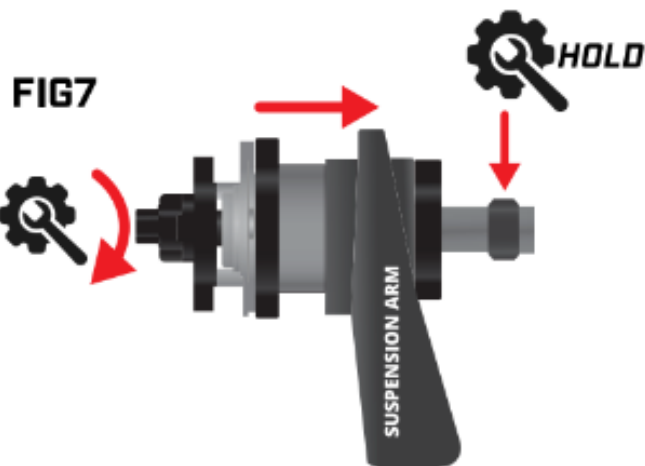

### Warranty

If you are unsure on how to use the item please contact us. If it were to fail due to a manufacturing fault or poor workmanship we will repair or replace it. Please contact your local dealer in the event you need to send the item back. You can also make a repair/replacement request on our website and download & complete the form online. Normal wear and tear along with misuse will void any warranty. Consumables are not covered under warranty.